

**KITTEN KT 50**



<b>Complete Rig Weight</b>	2t
<b>Access Width</b>	750mm
<b>Access Height</b>	1800mm
<b>Minimum Operating Width</b>	1000mm
<b>Typical operating Height Range</b>	1800mm-2650mm
<b>Rotary Head Torque output</b>	7500 Nm
<b>Max Retraction force</b>	40kN
<b>Max Crowd force</b>	15kN
<b>Power Pack Unit Type</b>	Remote Diesel – 60hp
<b>Power Pack Height / Width</b>	H 1500mm / W 1300mm
<b>Power Pack weight</b>	Max 1300 kg
<b>Maximum diameter of Clamping device</b>	350mm

4.0 TECHNICAL DETAILS

4.1 Complete machine

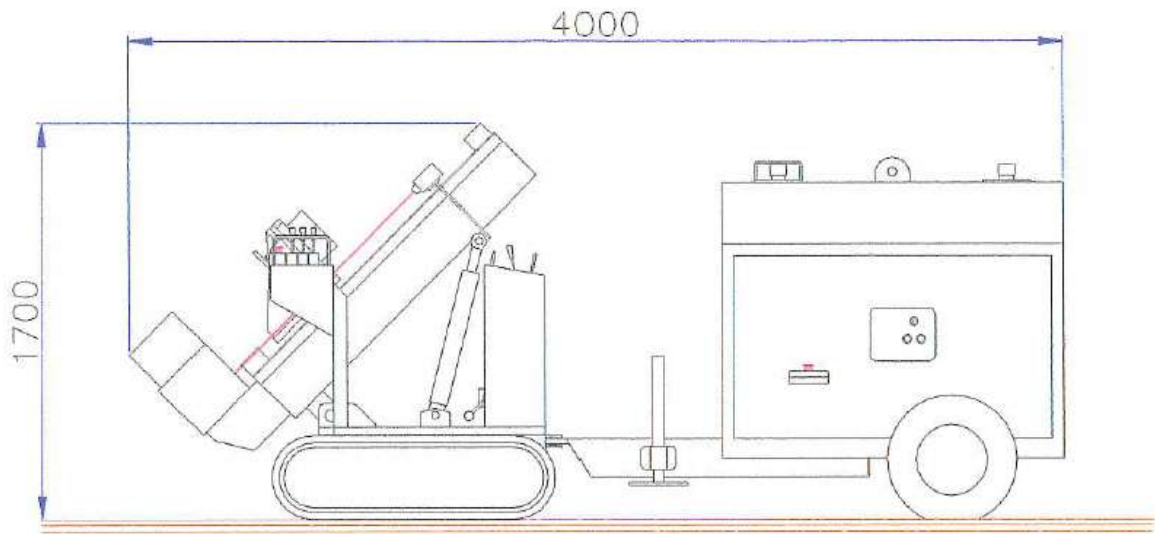

4.2 Kitten rig

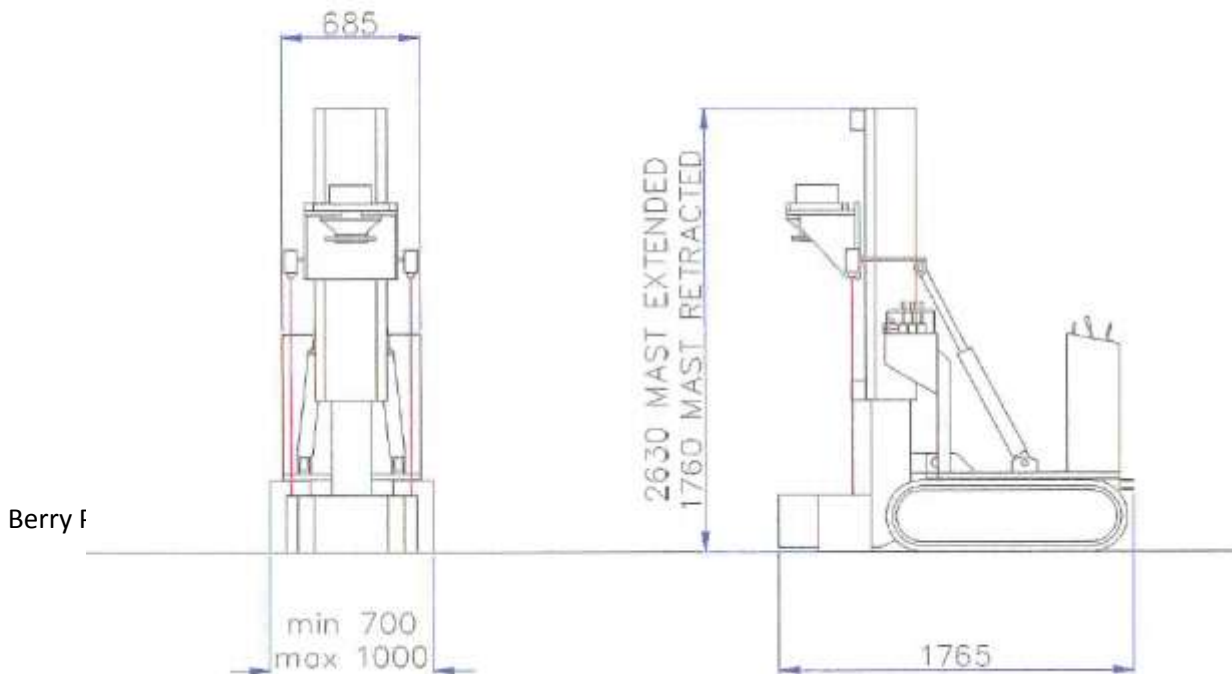

## Drilling Capabilities

Auger	260mm	320mm	350mm	450mm	600mm
Casing	300mm	345mm	390mm	508mm	660mm
Max. Drill Depth	20m	20m	18m	–	–
Max Cased Depth	8m	6m	-	–	–