

KLEMM 709 / 709-1



Weight	12t - 13t
Max power output	114/155 kW/hp - 129,5/176 kW/hp
Max ground bearing pressure	5,2 /cm2 - 4,7 N/cm2
Max Torque	30/40 Nm
Travelling speed	2.5km/h
Feed force	130kN
Retraction force (tear-out)	130kN
Feed Rate	4,9/10,5 m/min
Retraction rate	4,9/10,5 m/min
FAST Feed Rate	16,2 / 34,7 m/min
FAST Retraction rate	16,2 / 34,7 m/min
Feed Length	6000/2400mm

KR 709-1



Abmessungen / Dimensions mit Lafette Typ 202 (8000 mm) with drill mast type 202 (8000)

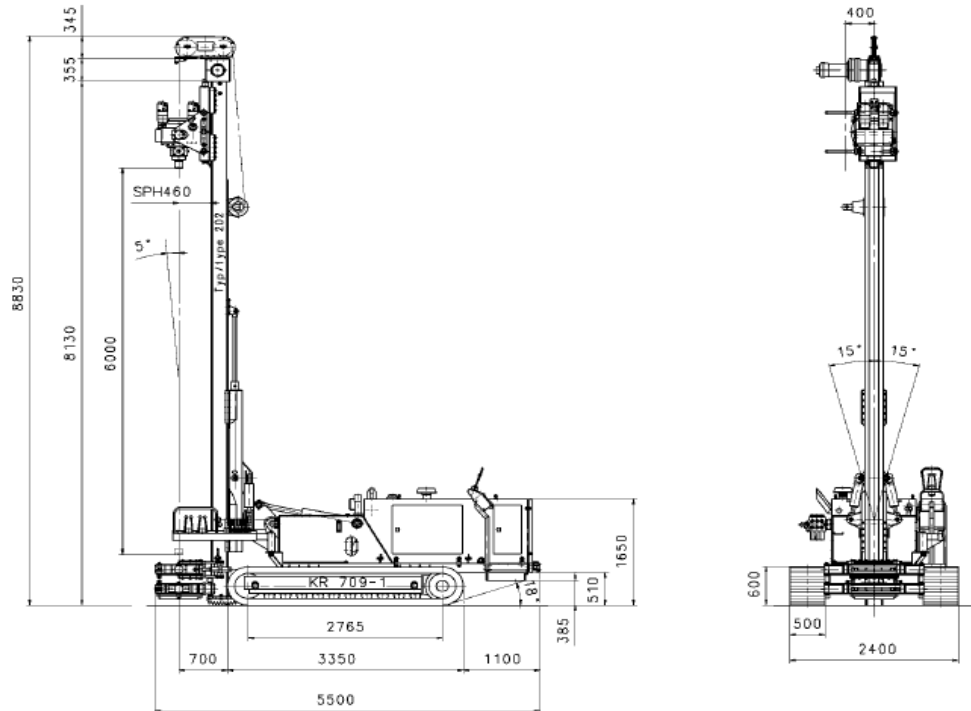

Transportabmessungen / Transport Dimensions

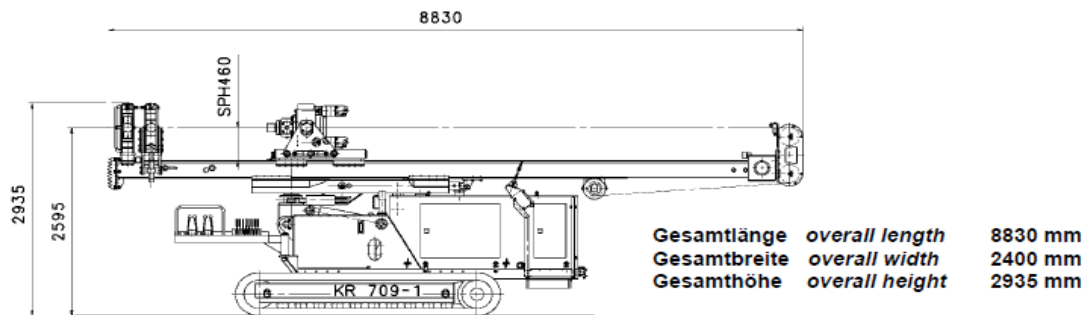

KR 709



Abmessungen / Dimensions mit Lafette Typ 202 (4400 mm) / with drill mast type 202 (4400 mm)

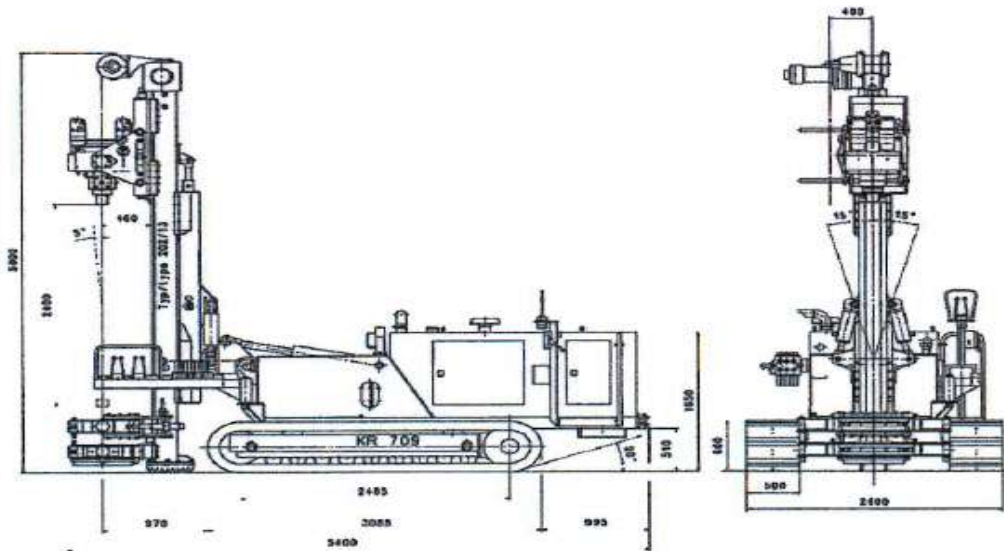

Transportabmessungen / Transport Dimensions mit Lafette Typ 202 (4400 mm) / with drill mast type 202 (4400 mm)

Gesamtlänge overall length 5140 mm
Gesamtbreite overall width 2400 mm
Gesamthöhe overall height 2935 mm

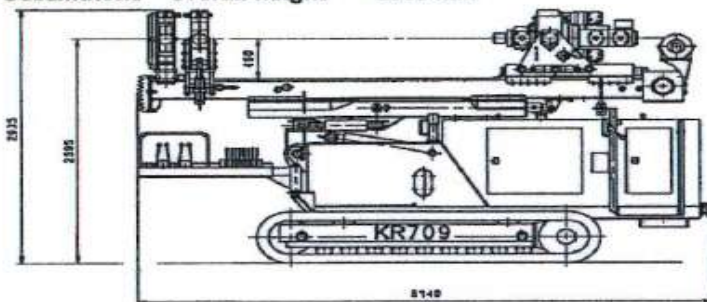

Drilling Capabilities

Auger	260mm	320mm	350mm	450mm	600mm
Casing	300mm	345mm	390mm	508mm	660mm
Max. Drill Depth	-	28m	28m	23m	20m
Max Cased Depth	-	12m	10m	10m	6m